

**TECHNICAL MANUAL**

**OPERATOR'S, ORGANIZATIONAL, DIRECT SUPPORT AND  
GENERAL SUPPORT MAINTENANCE MANUAL  
(INCLUDING REPAIR PARTS AND SPECIAL TOOLS LIST)  
FOR  
DEVIATION CALIBRATOR, 70D2-1MW and 70D2-2MW  
(COLLINS RADIO GROUP UNIT)  
(NSN 6625-00-450-4277)**

---

**HEADQUARTERS, DEPARTMENT OF THE ARMY**

**22 JANUARY 1980**

TECHNICAL MANUAL

No. 11-6625-2796-14&P

HEADQUARTERS  
DEPARTMENT OF THE ARMY  
WASHINGTON, DC 22 January 1980

**OPERATOR'S, ORGANIZATIONAL, DIRECT SUPPORT AND  
GENERAL SUPPORT MAINTENANCE MANUAL  
(INCLUDING REPAIR PARTS AND SPECIAL TOOLS LIST)  
FOR  
DEVIATION CALIBRATOR, 70D2-1MW and 70D2-2MW  
(COLLINS RADIO GROUP UNIT)  
(NSN 6625-0-450-4277)**

**REPORTING ERRORS AND RECOMMENDING IMPROVEMENTS**

You can help improve this manual. If you find any mistakes or if you know of a way to improve the procedures, please let us know.

Mail your letter or DA Form 2028 (Recommended Changes to Publications and Blank Forms), or DA Form 2028-2 direct to: Commander, US Army Communications and Electronics Materiel Readiness Command, ATTN: DRSEL-ME-MQ, Fort Monmouth, NJ 07703.

In any case, a reply will be furnished direct to you.

This manual is an authentication of the manufacturer's commercial literature which, through usage, has been found to cover the data required to operate and maintain this equipment. Since the manual was not prepared in accordance with military specifications and AR-310-3, the format has not been structured to consider levels of maintenance.

**Table of Contents**

SECTION		Page
	0. INTRODUCTION .....	0.1
	1. GENERAL DESCRIPTION .....	1
	2. UNIT CHARACTERISTICS .....	2
	3. CIRCUIT DESCRIPTION.....	2
	4. MAINTENANCE .....	4
	5. PARTS LIST .....	7
	6. PART NUMBER-NATIONAL STOCK NUMBER CROSS-REFERENCE INDEX ..	11
APPENDICES	A. REFERENCES .....	A-1
	B. MAINTENANCE ALLOCATION CHART .....	B-1
	C. DIFFERENCE DATA SHEET .....	C-1

**LIST OF TABLES**

Table 1	Unit Identification .....	2
---------	---------------------------	---

**LIST OF ILLUSTRATIONS**

Figure	Title	
1	70D2-2MW Deviation Calibrator .....	1
2	Typical Application .....	2
3	Simplified Block Diagram. ....	3
4	70D2-( ) MW, Schematic Diagram .....	*

\* A fold-in page, located in the back of the manual.

## SECTION 0. INTRODUCTION

### **0.1. Scope**

This manual describes the 70D2-1MW and 70D2-2MW Deviation Calibrator (fig. 1). Throughout this manual the equipment is referred to as the Deviation Calibrator.

### **0.2. Indexes of Publications**

a. DA Pam 310-4. Refer to the latest issue of DA Pam 310-4 to determine whether there are new editions, changes, or additional publications pertaining to the equipment.

b. DA Pam 310-7. Refer to DA Pam 310-7 to determine whether there are modification work orders (MWO's) pertaining to the equipment.

### **0.3. Maintenance Forms, Records, and Reports**

a. *Reports of Maintenance and Unsatisfactory Equipment.* Department of the Army forms and procedures used for equipment maintenance will be those described by TM 38-750, The Army Maintenance Management System.

b. *Report of Packaging and Handling Deficiencies.* Fill out and forward DD Form 6 (Packaging Improvement Report) as prescribed in AR 700-58/NAVSUPINST 4030.29/AFR 71-13/MCO P4030.29A and DLAR 4145.8.

c. *Discrepancy in Shipment Report (DISREP) (SF 361).* Fill out and forward Discrepancy in Shipment Report (DISREP) (SF 361) as prescribed in AR 55-38/NAVSUPINST 4610.33B/AFR 75-18/MCO P4610.19C and DLAR 4500.15.

### **0.4. Reporting Equipment Improvement Recommendations (EIR)**

If your 70D2-1MW and 70D2-2MW needs improvement, let us know. Send us an EIR. You, the user, are the only one who can tell us what you don't like about your equipment. Let us know why you don't like the design. Tell us why a procedure is hard to perform. Put it on an SF 368 (Quality Deficiency Report). Mail it to Commander, US Army Communications and Electronics Materiel Readiness Command, ATTN: DRSEL-ME-MQ, Fort Monmouth, NJ 07703. A reply will be furnished direct to you.

### **0.5. Administrative Storage**

Administrative storage of equipment issued to and used by Army activities shall be in accordance with TM 740-90-1.

### **0.6. Destruction of Army Electronics Materiel**

Destruction of Army electronics materiel to prevent enemy use shall be in accordance with TM 750-244-2.

## SECTION 1. GENERAL DESCRIPTION

### 1.1 Purpose of Unit

The deviation calibrators (figure 1) are normally used with other test equipment to adjust and calibrate the deviation sensitivity of an if. discriminator, which in turn may be used to set the deviation ratio of an associated

transmitter in a microwave system. See figure 2 for a typical application.

The units differ only in the deviation ratio of the calibrated output and the related frequency determining components. See table 1 for unit identification.

### 1.2 Unit Description

The deviation calibrators are transistorized, etched circuit, self-contained units mounted in a rigid cabinet with a carrying handle. Connectors,

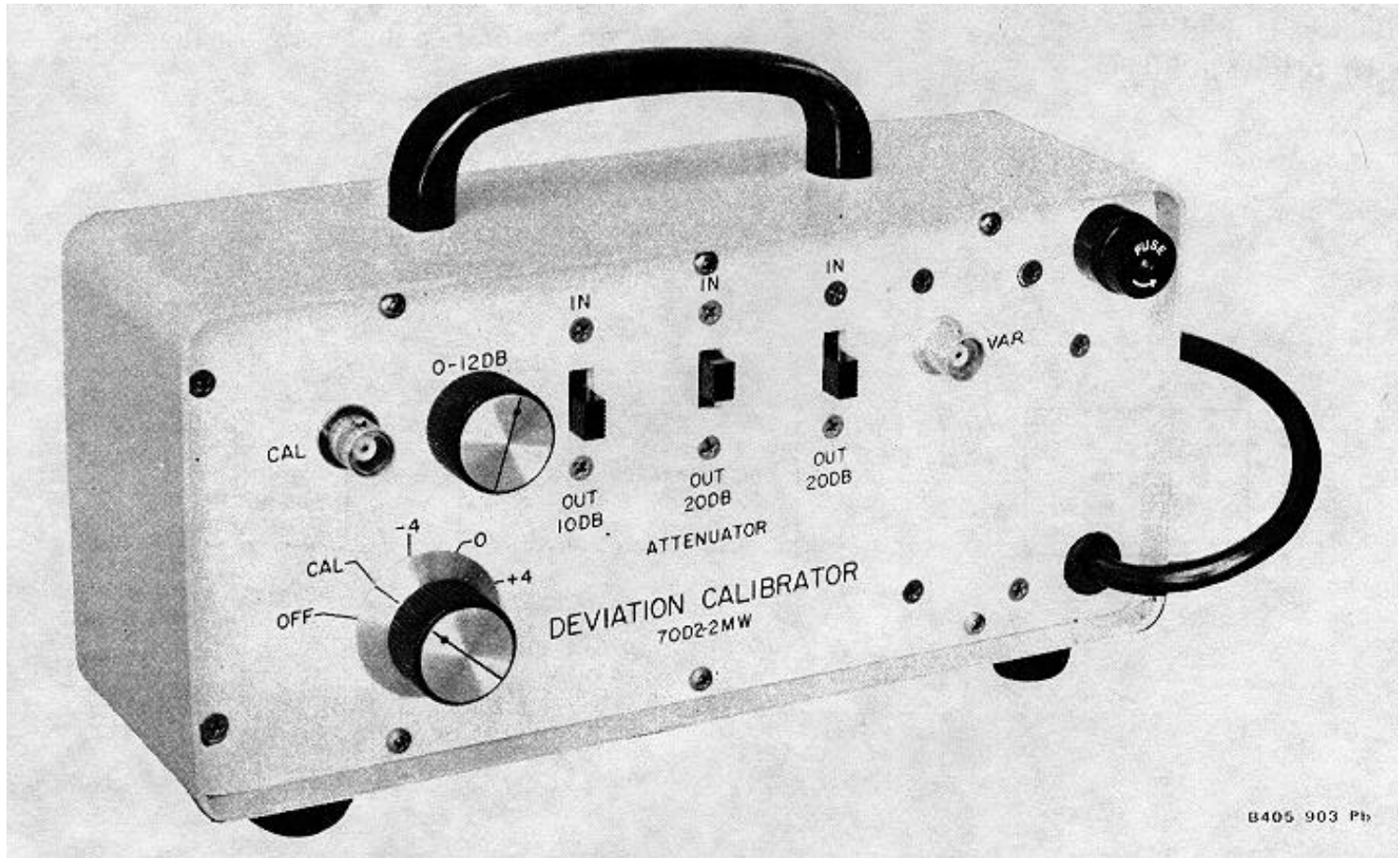

Figure 1. 70D2-2MW Deviation Calibrator.

controls, and switches are mounted on the control panel.  
A power cord is provided.

Table 1. Unit Identification.

UNIT	PART NUMBER	DEVIATION (MHz)
70D2-1MW	777-1142-001	±2.8
70D2-2MW	777-1143-001	±4.0

## SECTION 2. UNIT CHARACTERISTICS

### 2.1 Physical Characteristics

Size:

8 by 4 by 3 inches

Weight:

3 pounds

Finish:

Cabinet

Light gray

Panel

Off-white enamel

### 2.2 Operating Characteristics

Ambient Service Conditions:

Temperature

-30° to 50° C (- 22° to 122° F)

50° to 60°C (122° to 140°F) with slight performance degradation

Relative Humidity

Up to 95% at 50° C

Altitude

Up to 15,000 feet above MSL

Type of Service:

Continuous, unattended

### 2.3 Electrical Characteristics

Power Requirements:

115 volts ac, 50 to 60 Hz

Output Frequencies:

Unmodulated

67.2, 70, or 72.8 MHz (70D2-1MW)

66,70, or 74 MHz (70D2-2MW)

Modulated

Nominal 70 MHz, frequency-modulated with a 1- to 10-kHz square wave

Peak deviation 2.8 MHz (70D2- 1MW)

Peak deviation 4.0 MHz (70D2-2MW)

Signal Output Power:

CAL jack J1

Not less than 0 to 1 dbm each position of the function switch

VAR jack J2

- 10 to - 70 dbm, variable

## SECTION 3. CIRCUIT DESCRIPTION

The deviation calibrator generates a 70-MHz signal, frequency-modulated with a 1- to 10-kHz square wave.

The deviation of the square wave modulation is ± 2.8 MHz for the 70D2-1MW and ±4.0 MHz for the 70D2-2MW. Three crystal-controlled oscillators provide the accuracy required to calibrate an if. discriminator. See the schematic diagram.

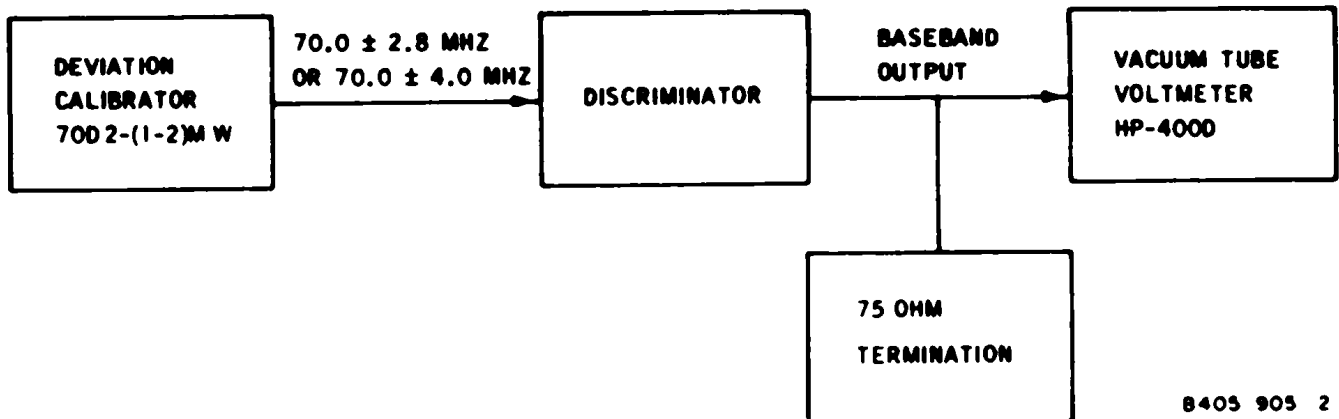

8405 905 2

Figure 2. Typical Application

Each deviation calibrator consists of a power supply, three crystal-controlled oscillators (Q1, Q2, and Q3), a multivibrator (Q4 and Q5), a diode switch (CR1 through CR4), a limiter amplifier (integrated circuit A1A1), a

calibration output amplifier (A1Q1 and A1Q2), and an auxiliary output amplifier (A1Q3 and A1Q4). The VAR output level is controlled by a variable attenuator and three switch-operated attenuators. See figure 3.

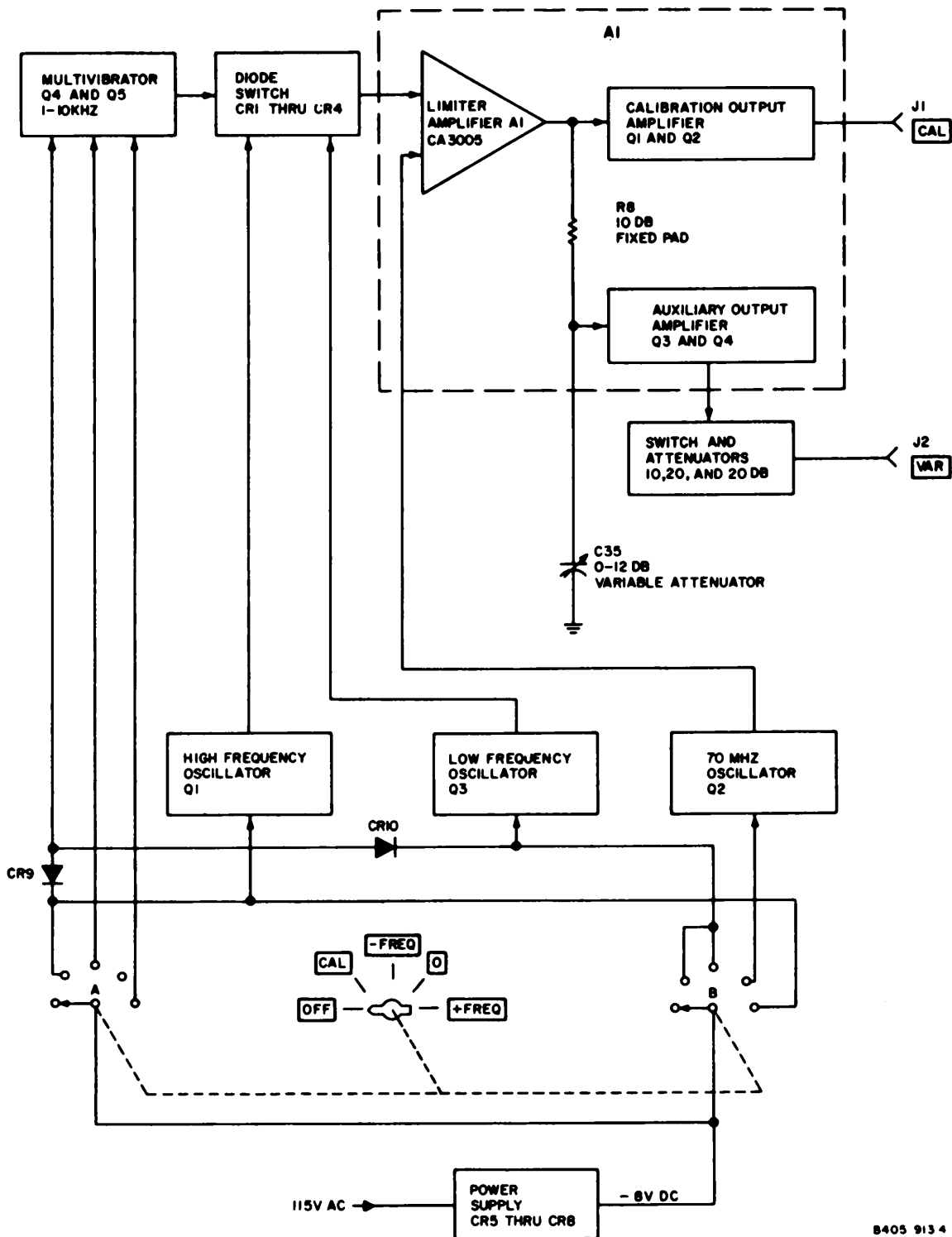

8405 913 4

Figure 3. Simplified Block Diagram.

Input power is coupled by power transformer T101 to the full-wave bridge power supply (CR5 through CR8). Capacitors C33 and C34 filter the -8-volt output of the bridge. The -8 volts is applied directly to the amplifier section (subassembly board AI) and through switch S101 to the oscillators, the multivibrator, and diodes CR9 and CR10.

**Note**

**Function switch S101 does not remove power from the power supply. When SO11 is OFF; only the oscillator circuits are disabled.**

Three crystal-controlled oscillators generate the required frequencies. Oscillator Q2 generates the 70-MHz frequency. Oscillator Q3 generates a frequency either 2.8 MHz (70D2-1MW) or 4 MHz (70D2-2MW) below 70 MHz. Oscillator Q1 generates a frequency either 2.8 MHz (70D2-1MW) or 4 MHz (70D2-2MW) above 70 MHz. The output of any one of the oscillators can be selected with S101.

The diode switch, CR1 through CR4, is biased or controlled by multivibrator Q4 and Q5. When S101 is set to -2.8 (70D2-1MW) or to -4 (70D2-2MW), -8 volts is applied through contact 7 of S101 to the base of Q4. This voltage locks the multivibrator (Q4 off and Q5 on), forward biasing CR1 and CR4 and reverse biasing CR2 and CR3. The -8 volts is also supplied as dc power to oscillator Q3 through contact 2 of S101. Diode CR10 prevents the -8 volts from being applied to oscillator Q1. The output of oscillator Q3 is applied through diode CR4 in the diode switch to limiter amplifier A1A1. The limiter amplifier drives both the calibration output amplifier (A1Q1 and A1Q2) and the auxiliary output amplifier (A1Q3 and A1Q4). The output from the calibration output amplifier is available at CAL jack J1. The output from the VAR output amplifier is applied through the ATTENUATOR network to VAR jack J2. Resistor R14 is used to adjust the gain of the calibration amplifier and thus set the output level at CAL jack J1.

When S101 is set to +2.8 (70D2-1MW) or +4 (70D2-2MW), -8 volts is applied through contact 9 of S101 to the base of Q5. This locks the multivibrator in the opposite state (Q4 on and Q5 off), forward biasing CR2

and CR3 and reverse biasing CR1 and CR4. The -8 volts is also supplied to oscillator Q1 through contact 4 of S101. Diode CR9 blocks the -8 volts from being applied to oscillator Q3. The output of oscillator Q1 is applied through diode CR3 in the diode switch to limiter amplifier A1A1 which drives both the calibration output amplifier and the auxiliary output amplifier.

When switch S101 is set to 0, -8 volts is supplied to oscillator Q2 only. Oscillators Q1 and Q3 and the multivibrator are disabled. The 70-MHz output of oscillator Q2 is applied directly to limiter amplifier A1A1. When S101 is set to CAL, -8 volts is supplied to oscillators Q1 and Q3 and to the multivibrator. Oscillator Q2 is disabled. The multivibrator is allowed to cycle normally, changing the bias on the diode switch each time it changes state. The outputs of Q1 and Q3 are switched alternately to the amplifier circuits, producing a 5.6-MHz (70D2-1MW) or 8-MHz (70D2-2MW) peak-to-peak square-wave modulated output at CAL jack J1 and VAR jack J2.

Capacitor C35 and resistor R8 form the 0-12DB variable attenuator. Resistors R22 through R24 form a fixed 10-db pad that can be switched in or out of the output circuit by 10DB IN/OUT switch S102. Resistors R25 through R27 and R28 through R30 form two 20-db fixed pads. These pads can be switched in or out of the output circuit by 20DB IN/OUT switches S103 and S104, respectively. The 70-MHz signal is available at both J1 and J2, but the level at J1 can not be adjusted from the control panel. The output at J2 must be terminated in 75 ohms in order for the attenuator pads to produce the correct value of attenuation.

The deviation calibrator is normally used with other test equipment in deviation sensitivity tests and adjustments. A calibrated discriminator may be used to set the deviation ratio of a microwave carrier. Refer to the appropriate System Maintenance Methods for the proper test setup and operating instructions.

## SECTION 4. MAINTENANCE

### **4.1 Recommended Test Equipment**

The following test equipment, or equivalent, is

recommended for troubleshooting and testing the unit.

Volt-Ohm-Milliammeter, Triplett 630-NA  
 Electronic Counter, Hewlett-Packard 5243L  
 Frequency Converter, Hewlett-Packard 5251A  
 RF Voltmeter, Boonton 91D  
 Termination, 75-ohm, Collins 713-0031-000  
 T-Connector, Collins 357-9314-000

**4.2 Troubleshooting**

Read the previous paragraphs, refer to the text figures, and study the schematic diagram so that circuit operation and unit characteristics are thoroughly understood. Perform the following procedure. The nature and location of any abnormal indications observed will aid in pinpointing the defective circuit or circuit element.

- a. Attempt to calibrate a spare discriminator in accordance with the System Maintenance Methods.
- b. Remove the unit from its case and place on a test bench for troubleshooting. Visually inspect the unit for loose connections and signs of component damage.
- c. Apply power to the unit and check for the voltages indicated on the schematic diagram.
- d. Remove power from the unit, and refer to the schematic diagram to perform resistance and continuity checks.
- e. Perform the steps in paragraph 4.3 for a complete bench test procedure.

**4.3 Bench Test Procedure**

The following steps provide a complete bench test procedure that is equivalent to the factory test procedure used on new units.

The deviation calibrators should be checked according to the following procedure after major repairs have been made or at intervals of 1 year.

- a. Remove the unit from the case.
- b. Connect the unit to a 115-volt ac source.
- c. Set the function switch to CAL. Set variable resistor R14 on subassembly board A1 to the midrange point.
- d. Connect the T-connector and a 75-ohm termination to the CAL jack. Connect the frequency counter to the T-connector. Connect a second 75-ohm termination to the VAR jack.
- e. Measure the power supply voltage at terminal 6 of S101. The voltage should be not less than -7.0 volts.

- f. Set S101 to -2.8 (70D2-1MW) or -4 (70D22MW).
- g. Adjust capacitors C21 and C24 for an indication on the frequency counter of 67.2 MHz +5.0 kHz (70D2-1MW) or 66 MHz +5 kHz (70D2-2MW).
- h. Disconnect the counter. Connect the 91D through the high impedance probe to the CAL jack. Adjust R14 (A1) for an output of 0.275 +0.010 volt rms.
- i. Disconnect the 91D, and connect the frequency counter to the CAL jack. Set S101 to 0.
- J. Adjust capacitors C13 and C16 for an indication of 70 MHz +5 kHz on the counter.
- k. Measure the output level at the CAL jack with the 91D. The 91D should indicate 0.275 +0.010 volt.
- l. Set the function switch to +2.8 (70D2-1MW) or +4 (70D2-2MW).
- m. Adjust capacitors C5 and C8 until the counter indicates 72.8 MHz +5.0 kHz (70D2-1MW) or 74 MHz +5 kHz (70D2-2MW).
- n. Measure the output level at the CAL jack with the 91D. The 91D should indicate 0.275 ±0.010 volt.
- o. Move the T-connector and termination to VAR jack J2. Connect the 91D to the T-connector through the high impedance probe. Set the attenuator switches to OUT and 0-12DB control C35 for minimum attenuation. Connect the second termination to the CAL jack.
- p. Set S101 to 0. The 91D should indicate not less than 0.070 volt. Note this level as a 0-db reference.
- q. Turn 0-12DB control C35 until the 91D indicates a minimum level. The level should decrease not less than 10 db below the reference in step p.
- r. Return 0-12DB control C35 to minimum attenuation.
- s. One at a time, switch the fixed attenuators into the output circuit and note the indication on the 91D. The increased attenuation should be 10 ±2 db for the 10DB attenuator and 20 ±2 db for each of the 20DB attenuators.
- t. Disconnect the test equipment. Replace the unit in the case.



#### 4.4 Repair

- a. Repair defective units by replacement of defective circuit elements. Always use good soldering techniques.
- b. After major repairs are made, perform the procedure in paragraph 4.3 to test and align the unit.
- c. Replace the unit in its case and calibrate a discriminator in accordance with the System Maintenance Methods.

## SECTION 5. PARTS LIST

SYMBOL	DESCRIPTION	MANUFACTURER'S PART NUMBER	MFR CODE	COLLINS PART NUMBER
	70D2-1MW DEVIATION CALIBRATOR			777-1142-001
	70D2-2MW DEVIATION CALIBRATOR			777-1143-001
A1	DEVIATION CALIBRATOR BOARD SEE BREAKDOWN ON PAGE 9			781-3687-001
C1	NOT USED			
C2	CAPACITOR, FXD, MICA 430 UUF, 5% TOL, 300 VDCW	D155F431J0	00853	912-2861-000
C3	CAPACITOR, FXD, MICA 100 UUF, 5% TOL, 500 VDCW	CM05FD101J3	81349	912-2816-000
C4	SAME AS C3			
C5	CAPACITOR, VAR, CERAMIC 2-8 UUF, 350 VDCW	538011C0P089R	72982	917-1218-000
C6	CAPACITOR, FXD, MICA 68 UUF, 5% TOL, 500 VDCW	CM05ED680J03	81349	912-2804-000
C7	CAPACITOR, FXD, MICA SELECTED 27 UUF OR 39 UUF OR 47 UUF OR 56 UUF	DI55E270K0 DI55E390K0 DI55E470K0 DI55E560K0	00853 00853 00853 00853	912-2775-000 912-2787-000 912-2793-000 912-2799-000
C8	CAPACITOR, VAR, CERAMIC 7-25 UUF, 350 VDCW	538011B2P093R	72982	917-1223-000
C9	CAPACITOR, FXD, CERAMIC 2200 UUF, PLUS 50% MINUS 20%, 500 VDCW	40C306	01939	913-3727-000
C10	SAME AS C2			
C11	SAME AS C3			
C12	SAME AS C3			
C13	SAME AS C5			
C14	CAPACITOR, FXD, MICA 75 UUF, 5% TOL, 500 VDCW	CM05ED750J03	81349	912-2807-000
C15	SAME AS C7			
C16	SAME AS C8			
C17	SAME AS C9			
C18	SAME AS C2			
C19	SAME AS C3			
C20	SAME AS C3			
C21	SAME AS C5			
C22	CAPACITOR, FXD, MICA 91 UUF, 5% TOL, 500 VDCW	CM05FD910J03	81349	912-2813-000
C23	SAME AS C7			
C24	SAME AS C8			
C25	CAPACITOR, FXD, CERAMIC 0.02 UF, PLUS 60% MINUS 40%, 250 VDCW	20C109	56289	913-2097-000
C26	SAME AS C25			
C27	SAME AS C9			
C28	SAME AS C9			
C29	SAME AS C23			
C30	CAPACITOR, FXD, MICA 270 UUF, 5% TOL, 500 VDCW	CM05FD271J03	81349	912-2846-000
C31	SAME AS C30			
C32	SAME AS C30			
C33	CAPACITOR, FXD, ELECTROLYTIC 100 UF, PLUS 100% MINUS 10%, 15 VDCW	D28902	56289	183-1380-000
C34	SAME AS C33			
C35	CAPACITOR, VAR, AIR 3 UUF MAX-MIN, 18.7 UUF	160-110-3	74970	922-0033-000
CR1	SEMICONDUCTOR DEVICE, DIODE	1N995	07688	353-2042-000
CR2	SAME AS CR1			
CR3	SAME AS CR1			
CR4	SAME AS CR1			
CR5	SEMICONDUCTOR DEVICE, DIODE	1N3253	07688	353-3274-000
CR6	SAME AS CR5			
CR7	SAME AS CR5			
CR8	SAME AS CR5			
CR9	SEMICONDUCTOR DEVICE, DIODE	1N645	07688	353-2607-000
CR10	SAME AS CR9			
FI	NOT USED			
THROUGH	NOT USED			
F100	NOT USED			
F101	FUSE, CARTRIDGE 1/8-AMP CURRENT RATING	F02B250V1-8AS	81349	264-4230-000

## SECTION 5. PARTS LIST - Continued

SYMBOL	DESCRIPTION	MANUFACTURER'S PART NUMBER	MFR CODE	COLLINS PART NUMBER
J1	CONNECTOR, ELECTRICAL 1 CONTACT	UG1094U	80058	357-9183-000
J2	SAME AS J1			
L1	COIL, RF 4.7 UH, 10% TOL	MS18130-16	96906	240-0793-000
L2	COIL, RF 0.15 UH, 20% TOL	MS18130-1	96906	240-0779-000
L3	SAME AS L1			
L4	COIL, RF 0.47 UH, 20% TOL	MS18130-4	96906	240-0782-000
L5	SAME AS L1			
L6	SAME AS L2			
L7	SAME AS L1			
L8	SAME AS L1A			
L9	SAME AS L1			
L10	SAME AS L2			
L11	SAME AS L1			
L12	SAME AS LA			
L13	COIL, RF 12 UH, 10% TOL	MS18130-21	96906	240-0798-000
L14	COIL, RF 10 UH, 10% TOL	MS18130-20	96906	240-0797-000
L15	SAME AS L14			
Q1	TRANSISTOR	2N1142	07688	352-0162-000
Q2	SAME AS Q1			
Q3	SAME AS Q1			
Q4	TRANSISTOR	2N697	07688	352-0197-000
Q5	SAME AS Q4			
R1	RESISTOR, FXD, COMPOSITION 1500 OHMS, 10% TOL, 1/4 WATT	RC07GF152K	81349	745-0755-000
R2	RESISTOR, FXD, COMPOSITION 150 OHMS, 10% TOL, 1/4 WATT	RC07GF151K	81349	745-0719-000
R3	SAME AS R2			
R4	SAME AS R1			
R5	SAME AS R2			
R6	SAME AS R2			
R7	SAME AS R1			
R8	SAME AS R2			
R9	SAME AS R2			
R10	RESISTOR, FXD, COMPOSITION 1K OHMS, 10% TOL, 1/4 WATT	RC07GF102K	81349	745-0749-000
R11	RESISTOR, FXD, COMPOSITION 27K OHMS, 10% TOL, 1/4 WATT	RC07GF273K	81349	745-0800-000
R12	SAME AS R11			
R13				
THROUGH R18	SAME AS R10			
R19	RESISTOR, FXD, COMPOSITION 680 OHMS, 10% TOL, 1/4 WATT	RC07GF681K	81349	745-0743-000
R20	NOT USED			
R21	NOT USED			
R22	RESISTOR, FXD, COMPOSITION 39 OHMS, 5% TOL, 1/4 WATT	RC07GF390J	81349	745-0697-000
R23	SAME AS R22			
R24	RESISTOR, FXD, COMPOSITION 51 OHMS, 5% TOL, 1/4 WATT	RC07GF510J	81349	745-0702-000
R25	RESISTOR, FXD, COMPOSITION 62 OHMS, 5% TOL, 1/4 WATT	RC07GF620J	81349	745-0705-000
R26	SAME AS R25			
R27	RESISTOR, FXD, COMPOSITION 15 OHMS, 5% TOL, 1/4 WATT	RC07GF150J	81349	745-0682-000
R28	SAME AS R25			
R29	SAME AS R25			
R30	SAME AS R27			
S1 THROUGH S100	NOT USED			
S101	SWITCH, ROTARY 1 SECTION, 2 POLES, 5 POSITIONS	24YY2601-5	81073	259-9419-000
S102	SWITCH, SLIDE DPDT CONTACT ARRANGEMENT	G326GCM0D	79727	266-0199-040

SECTION 5. PARTS LIST - Continued

SYMBOL	DESCRIPTION	MANUFACTURER'S PART NUMBER	MFR CODE	COLLINS PART NUMBER
S103 S104 T1 THROUGH T100 T101 XF1 THROUGH XF100 XF101  XY1 THROUGH XY100 XY101 XY102 XY103 Y1 THROUGH Y100 Y101	SAME AS S102 SAME AS S102 NOT USED TRANSFORMER, POWER, STEP DOWN NOT USED FUSEHOLDER 30-AMPS CURRENT RATING NOT USED SOCKET, CRYSTAL. SAME AS XY101 SAME AS XY101 NOT USED CRYSTAL UNIT, QUARTZ 72.80000 MHZ USED ON 70D2-1MW CRYSTAL UNIT, QUARTZ 74. 00000 MHZ USED ON 70D2-2MW CRYSTAL UNIT, QUARTZ 70. 00000 MHZ CRYSTAL UNIT, QUARTZ 67. 20000 MHZ USED ON 70D2-1MW CRYSTAL UNIT, QUARTZ 66. 00000 MHZ USED ON 70D2-2MW	P2945  HKPEHLQRWZ  8000AG2  BL289-6972-100 BL289-6972-100 BL289-6972-090 BL289-6972-080 BL289-6972-060	74042  71400  91506  71034 71034 71034 71034 71034	662-0199-010  265-1086-000  292-0215-000  289-6972-100 289-6972-120 289-6972-090 289-6972-080 289-6972-060
DEVIATION CALIBRATOR BOARD				781-3687-001
A1 C1  C2 THROUGH C5 C6  C7 C8 THROUGH C11 C12 C13 C14 C15 C16 L1 L2 L3 LA  L5 Q1 Q2 Q3 Q4 R1	INTEGRATED CIRCUIT CAPACITOR, FXD, CERAMIC 1000 UF, 20% TOL, 1000 VDCW SAME AS C1 CAPACITOR, FXD, MICA 15 UUF, 5% TOL, 500 VDCW SAME AS C6 SAME AS C1 SAME AS C6 SAME AS C1 SAME AS C1 SAME AS C1 SAME AS C6 COIL, RF 4.7UH, 10%TOL SAME AS L1 SAME AS L1 COIL, RF 0.22 UH, 20% TOL SAME AS L4A TRANSISTOR TRANSISTOR SAME AS Q1 SAME AS Q1 RESISTOR, FXD, COMPOSITION 470 OHMS, 10% TOL, 1/4 WATT	CA3005 CK60AW1D2M  CM05CD150J03  MS18130-16  MS18130-2  2N3563 2N3866  RC07GF471K	02735 81349  81349  96906  96906  07688 07688  81349	351-7188-010 913-1186-000  912-2759-000  240-0793-000  240-0780-000  352-0630-010 352-0671-010  745-0737-000

SECTION 5. PARTS LIST - Continued

SYMBOL	DESCRIPTION	MANUFACTURER'S PART NUMBER	MFR CODE	COLLINS PART NUMBER
R2	RESISTOR, FXD, COMPOSITION 5600 OHMS, 10% TOL, 1/4 WATT	RC07GF562K	81349	745-0776-000
R3	RESISTOR, FXD, COMPOSITION 820 OHMS, 10% TOL, 1/4 WATT	RC07GF821K	81349	745-0746-000
R4	SAME AS R3			
R5	SAME AS R2			
R6	RESISTOR, FXD, COMPOSITION 330 OHMS, 10% TOL, 1/4 WATT	RC07GF331K	81349	745-0731-000
R7	SAME AS R6			
R8	RESISTOR, FXD, COMPOSITION 1K OHMS, 10% TOL, 1/4 WATT	RC07GF102K	81349	745-0749-000
R9	SAME AS R2			
R10	RESISTOR, FXD, COMPOSITION 2700 OHMS, 10% TOL, 1/4 WATT	RC07GF272K	81349	745-0764-000
R11	SAME AS R6			
R12	RESISTOR, FXD, COMPOSITION 100 OHMS, 10% TOL, 1/4 WATT	RC07GF101K	81349	745-0713-000
R13	RESISTOR, FXD, COMPOSITION 10 OHMS, 10% TOL, 1/4 WATT	RC07GF100K	81349	745-0677-000
R14	RESISTOR, VAR, WIRE WOUND 100 OHMS, 5% TOL, 1 WATT	106-2100	75042	381-1830-000
R15	SAME AS R2			
R16	SAME AS R10			
R17	SAME AS R6			
R18	RESISTOR, FXD, COMPOSITION 22 OHMS, 10% TOL, 1/4 WATT	RC07GF220K	81349	745-0689-000
R19	RESISTOR, FXD, COMPOSITION 120 OHMS, 10% TOL, 1/4 WATT	RC07GF121K	81349	745-0716-000
T1	TRANSFORMER			758-4544-001

MANUFACTURERS CODES

CODE	MANUFACTURER			
00853	SANGAMO ELECTRIC CO PICKENS DIVISION PICKENS, S. C.			
01939	SPRAGUE ELECTRIC CO OF WISCONSIN GRAFTON, WIS			
02735	RADIO CORP OF AMERICA SOLID STATE AND RECEIVING TUBE DIVISION SOMERVILLE, N.J.			
07688	MILITARY SPECIFICATIONS			
56289	SPRAGUE ELECTRIC CO NORTH ADAMS, MASS.			
71034	BLILEY ELECTRIC CO ERIE, PA			
71400	BUSSMANN MFG DIVISION OF MCGRAW- EDISON CO ST LOUIS, MO			
72982	ERIE TECHNOLOGICAL PRODUCTS INC ERIE, PA			
74042	COIL AND TRANSFORMER CORP HOLLYWOOD, FLA			
74970	E F JOHNSON CO WASECA, MINN			
75042	IRC INC PHILADELPHIA, PA			
79727	CONTINENTAL WIRT ELECTRONICS CORP PHILADELPHIA, PA			
80058	MILITARY SPECIFICATIONS			
81073	GRAYHILL INC LA GRANGE, ILL.			
81349	MILITARY SPECIFICATIONS			
91506	AUGAT INC ATTLEBORO, MASS.			
96906	MILITARY SPECIFICATIONS			

SECTION 6.  
PART NUMBER - NATIONAL STOCK NUMBER  
CROSS REFERENCE INDEX

PART NUMBER	FSCM	NATIONAL STOCK NUMBER	PART NUMBER	FSCM	NATIONAL STOCK NUMBER	SMR CODE
CA3005	02735	5962-00-112-2468	2N3563	07688	5961-00-943-7572	
CK05BX223K	81349	5910-00-114-0510	2N3866	07688	5961-00-954-4864	
CM05CD150J03	81349	5910-00-936-7405	2N697	07688	5961-00-752-0150	
CM05ED680J03	81349	5910-00-227-6353	20C109	56289	5910-00-822-5233	
CM05ED750J03	81349	5910-00-227-7491	24C-0782-000	13499	5950-00-815-7306	
CM05FD271J03	81349	5910-00-460-0870	266-0199-040	13499	5930-00-498-5678	
COM05FD910J03	81349	5910-00-456-0810	351-7188-010	13499	5962-00-112-2468	
MS18130-1	96906	5950-00-769-4326	352-0197-000	13499	5961-00-752-0150	
MS18130-16	96906	5950-00-724-6214	352-0630-010	13499	5961-00-943-7572	
MS18130-2	96906	5950-00-764-3186	353-3274-000	13499	5961-00-964-5478	
MS18130-20	96906	5950-00-707-1243	538011C0P089R	72982	5910-00-767-4977	
MS18130-21	96906	5950-00-899-9359	758-4544-001	13499	5950-00-823-9963	
MS18130-4	96906	5950-00-764-3188	8000AG2	91506	5935-00-866-4298	
P2945	74042	5950-00-059-8744	912-2813-000	13499	5910-00-725-7426	
RC07GF100K	81349	5905-00-465-9557	912-2861-000	13499	5910-00-023-2068	
RC07GF101K	81349	5905-00-726-5340	913-3727-000	13499	5910-00-763-9987	
RC07GF102K	81349	5905-00-752-3338	917-1223-000	13499	5910-00-422-0502	
RC07GF121K	81349	5905-00-982-5503	922-0033-000	13499	5910-00-192-2406	
RC07GF150J	81349	5905-00-721-1488				
RC07GF151K	81349	5905-00-752-3336				
RC07GF152K	81349	5905-00-726-5343				
RC07GF220K	81349	5905-00-892-6555				
RC07GF272K	81349	5905-00-686-4527				
RC07GF273K	81349	5905-00-752-3157				
RC07GF331K	81349	5905-00-726-6435				
RC07GF390J	81349	5905-00-820-9124				
RC07GF471K	81349	5905-00-686-4526				
RC07GF510J	81349	5905-00-683-7720				
RC07GF562K	81349	5905-00-726-6834				
RC07GF620J	81349	5905-00-835-1635				
RC07GF681K	81349	5905-00-726-6837				
RC07GF821K	81349	5905-00-755-0796				

**APPENDIX A  
REFERENCES**

---

DA Pam 310-4	Index of Technical Publications: Technical Manuals, Technical Bulletins, Supply Manuals, (Types 7, 8 and 9), Supply Bulletins, and Lubrication Orders.
DA Pam 310-7	US Army Equipment Index of Modification Work Orders.
TM 38-750	The Army Maintenance Management System (TAMMS).
TM 740-90-1	Administrative Storage of Equipment.
TM 750-244-2	Procedures for Destruction of Electronics Materiel to Prevent Enemy Use (Electronics Command).

## APPENDIX B

### MAINTENANCE ALLOCATION

---

#### Section I. INTRODUCTION

##### B-1. General

This appendix provides a summary of the maintenance operations for 70D2- 1MW and 70D2-2MW. It authorizes categories of maintenance for specific maintenance functions on repairable items and components and the tools and equipment required to perform each function. This appendix may be used as an aid in planning maintenance operations.

##### B-2. Maintenance Function

Maintenance functions will be limited to and defined as follows:

*a. Inspect.* To determine the serviceability of an item by comparing its physical, mechanical, and/or electrical characteristics with established standards through examination.

*b. Test.* To verify serviceability and to detect incipient failure by measuring the mechanical or electrical characteristics of an item and comparing those characteristics with prescribed standards.

*c. Service.* Operations required periodically to keep an item in proper operating condition; i.e., to clean (decontaminate), to preserve, to drain, to paint, or to replenish fuel, lubricants, hydraulic fluids, or compressed air supplies.

*d. Adjust.* To maintain, within prescribed limits, by bringing into proper or exact position, or by setting the operating characteristics to the specified parameters.

*e. Align.* To adjust specified variable elements of an item to bring about optimum or desired performance.

*f. Calibrate.* To determine and cause corrections to be made or to be adjusted on instruments or test measuring and diagnostic equipments used in precision measurement. Consists of comparisons of two instruments, one of which is a certified standard of known accuracy, to detect and adjust any discrepancy in the accuracy of the instrument being compared.

*g. Install.* The act of emplacing, seating, or fixing into position an item, part, module (component or assembly) in a manner to allow the proper functioning of the equipment or system.

*h. Replace.* The act of substituting a serviceable like type part, subassembly, or module (component or assembly) for an unserviceable counterpart.

*i. Repair.* The application of maintenance services (inspect, test, service, adjust, align, calibrate, replace) or other maintenance actions (welding, grinding, riveting, straightening, facing, remachining, or

resurfacing) to restore serviceability to an item by correcting specific damage, fault, malfunction, or failure in a part, subassembly, module (component or assembly), end item, or system.

*j. Overhaul.* That maintenance effort (service/action) necessary to restore an item to a completely serviceable/operational condition as prescribed by maintenance standards (i.e., DMWR) in appropriate technical publications. Overhaul is normally the highest degree of maintenance performed by the Army. Overhaul does not normally return an item to like new condition.

*k. Rebuild.* Consists of those services/actions necessary for the restoration of unserviceable equipment to a like new condition in accordance with original manufacturing standards. Rebuild is the highest degree of materiel maintenance applied to Army equipment. The rebuild operation includes the act of returning to zero those age measurements (hours, miles, etc.) considered in classifying Army equipments/components.

##### B-3. Column Entries

*a. Column 1, Group Number.* Column 1 lists group numbers, the purpose of which is to identify components, assemblies, subassemblies, and modules with the next higher assembly.

*b. Column 2, Component/Assembly.* Column 2 contains the noun names of components, assemblies, subassemblies, and modules for which maintenance is authorized.

*c. Column 3, Maintenance Functions.* Column 3 lists the functions to be performed on the item listed in column 2. When items are listed without maintenance functions, it is solely for purpose of having the group numbers in the MAC and RPSTL coincide.

*d. Column 4, Maintenance Category.* Column 4 specifies, by the listing of a "work time" figure in the appropriate subcolumn(s), the lowest level of maintenance authorized to perform the function listed in column 3. This figure represents the active time required to perform that maintenance function at the indicated category of maintenance. If the number of complexity of the tasks within the listed maintenance



function vary at different maintenance categories, appropriate "work time" figures will be shown for each category. The number of task-hours specified by the "work time" figure represents the average time required to restore an item (assembly, subassembly, component, module, end item or system) to a serviceable condition under typical field operating conditions. This time includes preparation time, troubleshooting time, and quality assurance/quality control time in addition to the time required to perform the specific tasks identified for the maintenance functions authorized in the maintenance allocation chart. Subcolumns of column 4 are as follows:

- C-Operator/Crew
- O-Organizational
- F-Direct Support
- H-General Support
- D-Depot

e. *Column 5, Tools and Equipment.* Column 5 specifies by code, those common tool sets (not individual tools) and special tools, test, and support equipment required to perform the designated function.

f. *Column 6, Remarks.* Not applicable.

#### **B-4. Tool and Test Equipment Requirements (Sec III)**

a. *Tool or Test Equipment Reference Code.* The numbers in this column coincide with the numbers used in the tools and equipment column of the MAC. The numbers indicate the applicable tool or test equipment for the maintenance functions.

b. *Maintenance Category.* The codes in this column indicate the maintenance category allocated the tool or test equipment.

c. *Nomenclature.* This column lists the noun name and nomenclature of the tools and test equipment required to perform the maintenance functions.

d. *National/NATO Stock Number.* This column lists the National/NATO stock number of the specific tool or test equipment.

e. *Tool Number.* This column lists the manufacturer's part number of the tool followed by the Federal Supply Code for manufacturers (5-digit) in parentheses.

#### **B-5. Remarks (Sec IV)**

Not applicable.

**SECTION II MAINTENANCE ALLOCATION CHART  
FOR  
DEVIATION CALIBRATOR, 70D2-1MW AND 70D2-2MW**

(1) GROUP NUMBER	(2) COMPONENT/ ASSEMBLY	(3) MAINT. FUNCTION	(4) MAINTENANCE CATEGORY					(5) TOOLS AND EQUIP	(6) REMARKS
			C	O	F	H	D		
00	DEVIATION CALIBRATOR 70D2-1MW AND 70D2-2MW	Inspect		0.5				9	
		Replace		0.5					
		Inspect				0.5			
		Test				1.5		1 thru 8	
		Repair				2.0		7,8,9	
		Replace				0.5		8	
01	POWER SUPPLY	Adjust				1.0		9	
		Overhaul					3.5	1 thru 8	
02	LINE CORD	Test				0.5		1	
		Repair				1.0		7,8	
		Repair				1.0		8	

**SECTION III TOOL AND TEST EQUIPMENT REQUIREMENTS  
FOR  
DEVIATION CALIBRATOR 70D2-1MW and 70D2-2MW**

Tool or Test Equipment Ref Code	Maintenance Category	Nomenclature	National/NATO Stock Number	Tool Number
1	H,D	MULTIMETER AN/USM-223	6625-00-999-7465	
2	H,D	ELECTRONIC COUNTER CD-772A/U (H.P. 52451)	6625-00-973-4837	
3	H,D	FREQUENCY CONVERTER CV-2002/U	6625-00-266-3483	
4	H,D	R. F. VOLTMETER AN/USM-145 (w/high Imp Probe)	6625-00-973-3986	
5	H,D	TERMINATION 75 OHM, COLLINS 713-0031-0(0		
6	H,D	T-CONNECTOR, COLLINS 357-9314-000		
7	H,D	MAINTENANCE KIT MK-772/U	5999-00-757-7042	
8	H,D	TOOL KIT, ELECTRONIC EQUIPMENT TK-100/G	5180-00-605-0079	
9	O,H	TOOLS AND TEST EQUIPMENT AVAILABLE TO THE REPAIRMAN USER  BECAUSE OF HIS ASSIGNED TASK.		

**APPENDIX C  
DIFFERENCE DATA SHEET  
FOR  
70D2-(1-2)MW  
DEVIATION CALIBRATOR**

**CHANGE NOTICE NO. 1  
Unit Instructions 523-0557786-001A38, dated 1 December 1968**

**ISSUE D\* CHANGES**

Capacitors C25 and C26, and resistors R11 and R12 have been changed to produce a more symmetrical square wave and improve circuit performance. The parts list and schematic diagram should reflect these changes. See table 1.

Table 1.

SYMBOL	DESCRIPTION	MFR PART NUMBER	MFR CODE	COLLINS PART NUMBER
C25	CAPACITOR, FXD, CERAMIC 0.022 UF, 10% TOL, 50 VDCW	CK05BX223K	81349	913-5019-240
C26	SAME AS C25			
R11	RESISTOR, FXD, FILM 27 KILOHMS, 2% TOL, 1/4 WATT	RL027S273	81349	745-4325-000
R12	SAME AS R11			

---

\*A decal attached to the module identifies the status of the unit. The decal is stamped with either an issue letter or a 3-number date code. The issue letter coincides with the revision of the schematic diagram. The first number of the date code is the last number of the Collins fiscal year, and the last two numbers indicate the fiscal week this change became effective.

**C-1/(C-2 blank)**

☆U.S. GOVERNMENT PRINTING OFFICE: 1993 - 342-421/62552

**NOTICE**  
 This document contains data developed at the private expense of Collins Radio Company and is furnished under contract or agreement between Collins Radio Company and the recipient hereof upon the condition that the contents of this document shall not be disclosed, copied, duplicated, disseminated, or used except for purposes authorized by contract or otherwise expressly authorized in writing. This notice is void when a "Limited Rights" legend also appears on the data.

REVISIONS			
SYM	DESCRIPTION	DATE	APPROVAL
A	T-69373: C15 WAS 39PF, ADDED CR9 & CR10	28 NOV 1967	PLW
B	T-77755: Q2 WAS 2N3568	21 JUN 1968	WJ
C	T-92894: ADDED NOTE 6 & C23 WAS 47PF	6 DEC 1968	JH

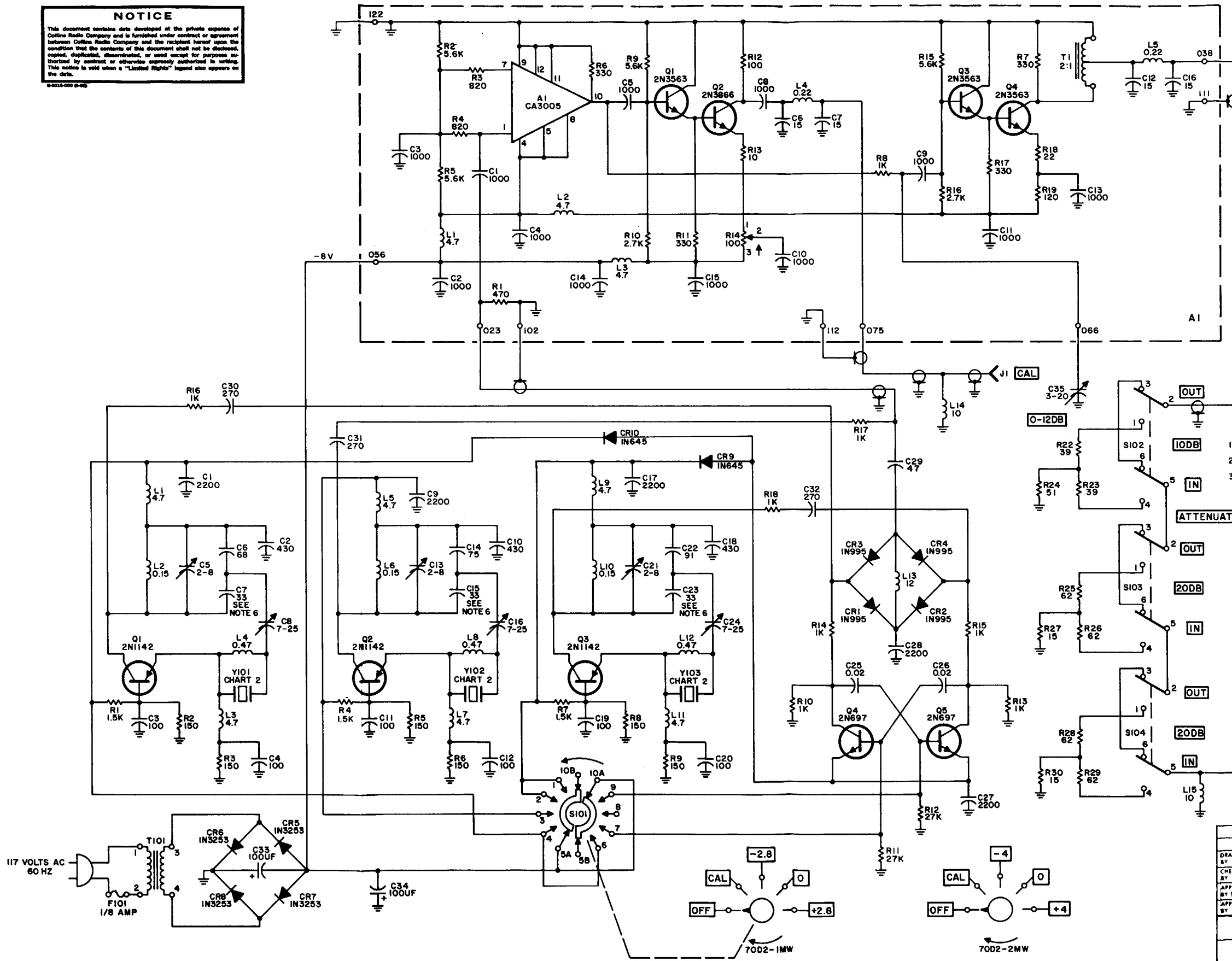

CHART 1  
 TRANSISTOR DC VOLTAGES

Q NO.	EMITTER	BASE	COLLECTOR
Q1A1	-6.05	-5.2	0
Q2A1	-6.8	-6.05	-0.71
Q3A1	-6.08	-5.4	0
Q4A1	-6.8	-6.05	0
Q1	-0.5	-0.8	-8.8
Q2	-0.5	-0.8	-9.3
Q3	-0.5	-0.8	-8.8
Q4	-8.8	-8	-7.5
Q5	-8.8	-8	-7.5

CHART 2

NEXT ASSY	UNIT	Y101	Y102	Y103	DEV.
777-1142-001	70D2-1MW	72.8MHZ	70.0MHZ	67.2MHZ	+2.8MHZ
777-1143-001	70D2-2MW	74.0MHZ	70.0MHZ	66.0MHZ	4MHZ

- NOTES:
- UNLESS OTHERWISE INDICATED, ALL RESISTANCE VALUES ARE IN OHMS, K=1000, ALL CAPACITANCE VALUES ARE IN MICROFARADS, ALL INDUCTANCE VALUES ARE IN MICROHENRIES
  - SOLID BOXES INDICATE SYMBOLIZATION ON FRONT OF UNIT
  - WAFER SWITCHES DRAWN AS VIEWED FROM REAR, KNOBS AS VIEWED FROM FRONT
  - DC VOLTAGES MEASURED WITH CRYSTALS REMOVED
  - DIRECTION OF ROTATION INDICATED FOR VARIABLE RESISTOR IS CLOCKWISE
  - C7, 15 AND 23 MAY BE SELECTED AS ONE OF THE FOLLOWING; 27PF, 33PF, 39PF, 47PF, & 56PF. 33PF WILL BE PRE-MOUNTED

AUTHENTICATION		SEE CHART 2	
NAME	DATE	DASH	NEXT ASSY. EQUIP.
DRAWN BY: D. STEVENSON	19 MAY 1967		
CHECKED BY: <i>R. Kester</i>	19 MAY 1967		
APPROVED BY: <i>W.D. [Signature]</i>	19 MAY 1967		
APPROVED BY: <i>LEH [Signature]</i>	19 MAY 1967		
COLLINS RADIO COMPANY CEDAR RAPIDS, IOWA (DALLAS, TEXAS DIV.)		APPLICATION	
		SCHEMATIC DIAGRAM, DEVIATION CALIBRATOR- 70D2-() MW	
CODE IDENT NO	SIZE	781-3622-001	
13499	D		
SCALE NONE	WT	SHEET	

Figure 4. 70D2-() MW, Schematic Diagram.

By Order of the Secretary of the Army:

E. C. MEYER  
*General, United States Army*  
*Chief of Staff*

Official:

J. C. PENNINGTON  
*Major General, United States Army*  
*The Adjutant General*

Distribution:

*Active Army:*

HISA (Ft Monmouth)(21)  
USAINSCOM (2)  
COE (1)  
TSG (1)  
USAARENBD(1)  
DARCOM (1)  
TRADOC (2)  
OS Maj Cmd (4)  
TECOM (2)  
USACC (4)  
MDW(1)  
Armies (2)  
Corps (2)  
Svc Colleges (1)  
USASIGS (5)  
USAADS (2)  
USAFAS(2)  
USAARMS (2)  
USAIS (2)  
USAES (2)  
USAICS (3)  
MAAG (1)  
USARMIS (1)  
USAERDAA (1)  
USAERDAW (1)  
Ft Gordon (10)  
Ft Carson (5)  
Army Dept (1) except  
    LBAD(14)  
    SAAD (30)  
    TOAD (14)  
    SHAD (3)  
Ft Gillem(10)  
USA Dep (1)  
Sig Sec USA Dep (1)  
Ft Richardson (CERCOM Ofc) (2)  
Units org under fol TOE:  
    29-207 (2)  
    29-610(2)

NG: None

USAR: None.

For explanation of abbreviations used, see AR 310-50.

RECOMMENDED CHANGES TO EQUIPMENT TECHNICAL PUBLICATIONS



*THEN...JOT DOWN THE DOPE ABOUT IT ON THIS FORM. CAREFULLY TEAR IT OUT, FOLD IT AND DROP IT IN THE MAIL.*

**SOMETHING WRONG WITH PUBLICATION**

FROM: (PRINT YOUR UNIT'S COMPLETE ADDRESS)

DATE SENT

PUBLICATION NUMBER

PUBLICATION DATE

PUBLICATION TITLE

BE EXACT PIN-POINT WHERE IT IS

PAGE NO.	PARA-GRAPH	FIGURE NO.	TABLE NO.

IN THIS SPACE, TELL WHAT IS WRONG AND WHAT SHOULD BE DONE ABOUT IT.

PRINTED NAME, GRADE OR TITLE AND TELEPHONE NUMBER

SIGN HERE

## The Metric System and Equivalents

### *Linear Measure*

1 centimeter = 10 millimeters = .39 inch  
 1 decimeter = 10 centimeters = 3.94 inches  
 1 meter = 10 decimeters = 39.37 inches  
 1 dekameter = 10 meters = 32.8 feet  
 1 hectometer = 10 dekameters = 328.08 feet  
 1 kilometer = 10 hectometers = 3,280.8 feet

### *Weights*

1 centigram = 10 milligrams = .15 grain  
 1 decigram = 10 centigrams = 1.54 grains  
 1 gram = 10 decigrams = .035 ounce  
 1 decagram = 10 grams = .35 ounce  
 1 hectogram = 10 decagrams = 3.52 ounces  
 1 kilogram = 10 hectograms = 2.2 pounds  
 1 quintal = 100 kilograms = 220.46 pounds  
 1 metric ton = 10 quintals = 1.1 short tons

### *Liquid Measure*

1 centiliter = 10 milliliters = .34 fl. ounce  
 1 deciliter = 10 centiliters = 3.38 fl. ounces  
 1 liter = 10 deciliters = 33.81 fl. ounces  
 1 dekaliter = 10 liters = 2.64 gallons  
 1 hectoliter = 10 dekaliters = 26.42 gallons  
 1 kiloliter = 10 hectoliters = 264.18 gallons

### *Square Measure*

1 sq. centimeter = 100 sq. millimeters = .155 sq. inch  
 1 sq. decimeter = 100 sq. centimeters = 15.5 sq. inches  
 1 sq. meter (centare) = 100 sq. decimeters = 10.76 sq. feet  
 1 sq. dekameter (are) = 100 sq. meters = 1,076.4 sq. feet  
 1 sq. hectometer (hectare) = 100 sq. dekameters = 2.47 acres  
 1 sq. kilometer = 100 sq. hectometers = .386 sq. mile

### *Cubic Measure*

1 cu. centimeter = 1000 cu. millimeters = .06 cu. inch  
 1 cu. decimeter = 1000 cu. centimeters = 61.02 cu. inches  
 1 cu. meter = 1000 cu. decimeters = 35.31 cu. feet

## Approximate Conversion Factors

<i>To change</i>	<i>To</i>	<i>Multiply by</i>	<i>To change</i>	<i>To</i>	<i>Multiply by</i>
inches	centimeters	2.540	ounce-inches	Newton-meters	.007062
feet	meters	.305	centimeters	inches	.394
yards	meters	.914	meters	feet	3.280
miles	kilometers	1.609	meters	yards	1.094
square inches	square centimeters	6.451	kilometers	miles	.621
square feet	square meters	.093	square centimeters	square inches	.155
square yards	square meters	.836	square meters	square feet	10.764
square miles	square kilometers	2.590	square meters	square yards	1.196
acres	square hectometers	.405	square kilometers	square miles	.386
cubic feet	cubic meters	.028	square hectometers	acres	2.471
cubic yards	cubic meters	.765	cubic meters	cubic feet	35.315
fluid ounces	milliliters	29.573	cubic meters	cubic yards	1.308
pints	liters	.473	milliliters	fluid ounces	.034
quarts	liters	.946	liters	pints	2.113
gallons	liters	3.785	liters	quarts	1.057
ounces	grams	28.349	liters	gallons	.264
pounds	kilograms	.454	grams	ounces	.035
short tons	metric tons	.907	kilograms	pounds	2.205
pound-feet	Newton-meters	1.356	metric tons	short tons	1.102
pound-inches	Newton-meters	.11296			

## Temperature (Exact)

°F	Fahrenheit temperature	5/9 (after subtracting 32)	Celsius temperature	°C
----	------------------------	----------------------------	---------------------	----



**PIN: 044429-000**